

Crystal USB 3.0

External Storage for 3.5-inch Hard Drive

Delivering 10 times faster processing speed



User's Manual

USB 2.0/3.0

Please go onto Data Watch's website at <http://www.datawatchtech.com> for the latest version of user manual.



Table of Contents

GENERAL INFORMATION	3
Copyright.....	3
Notices and Classifications	3
Contact Us.....	3
 PRECAUTIONS FOR THE ENCLOSURE	4
INTRODUCTION	5
Features	5
SYSTEM REQUIREMENT	6
<i>PC</i>	6
<i>MAC</i>	6
Optional Accessories	6
PACKAGE CONTENTS.....	6
<i>HU-M10J</i>	6
SYSTEM UNIT VIEWS.....	7
Rear/Front View.....	7
Bottom View	7
Inside View.....	7
ASSEMBLING THE ENCLOSURE	8
PUTTING ON & SWITCHING POWER PLUG ON AC/DC ADAPTER.....	10
CONNECTING THE ENCLOSURE UNIT TO A COMPUTER.....	11
LED STATUS	12
SAFE REMOVAL OF THE ENCLOSURE	12
EXTERNAL BOOTUP	12
<i>PC</i>	12
<i>MAC</i>	12
Q&As	13
Hard Drive Capacity.....	13
Discrepancy in Reported & Actual Size Capacity.....	13
APPENDIX: SPECIFICATIONS.....	15

GENERAL INFORMATION

Copyright

Copyright © 2011 Data Watch Technologies Co., Ltd. All rights reserved. No part of this publication may be reproduced, stored in a retrieval system, or transmitted in any form or by any means, electronic, mechanical, photocopying, recording or otherwise, without the prior written consent of Data Watch Technologies Co., Ltd or ONNTO Corporation.



The product information provided in this manual is subject to change without prior notice and does not represent a commitment on behalf of the vendor. The vendor assumes no liability or responsibility for any errors that may appear in this manual.

Notices and Classifications

FCC-B Radio Frequency Interference Statement

This device complies with Part 15 of the FCC rules. Operation is subject to the following two conditions:

This device may not cause harmful interference.

This device must accept any interference received, including interference that may cause undesired operation.



This equipment has been tested and found to comply with the limits for a Class B digital device, pursuant to Part 15 of the FCC rules. These limits are designed to provide reasonable protection against harmful interference when the equipment is operated in a commercial environment. This equipment generates uses and can radiate radio frequency energy and, if not installed and used in accordance with the instruction manual, may cause harmful interference to radio communications.

Contact Us

We are committed to offer economical, high-quality connectivity and storage enclosure solutions to the market. Your questions, inquiries or comments are welcomed. For the latest version of User Manual & Technical Support, please go to our website at www.data-tale.com

Data Watch Technologies Co., Ltd.

3F, No. 60, Lane 321, Yang Guang St.,

Nei Hu, Taipei 114 Taiwan

Tel: +886-2-8797-8868

Fax: +886-2-8797-4801

Email: info@datawatchtech.com



PRECAUTIONS FOR THE ENCLOSURE

- ◆ The main circuit board of the Enclosure is susceptible to static electricity. Proper grounding is required to prevent electrical damage to the Enclosure or other connected devices, including the host computer. **Always** place the Enclosure on a smooth surface and avoid all dramatic movement, vibration and percussion.
- ◆ Do **NOT** allow water to enter the Enclosure.
- ◆ Installation of additional equipment in the host computer may be required. Visit our website to download the latest product information updates.
- ◆ Do **NOT** attempt to service this device yourself. Disassembling the Enclosure's inner parts will expose you to dangerous voltages or other hazards.
- ◆ Do **NOT** block the ventilation. Proper airflow is required to ensure reliable operation and to prevent overheating.
- ◆ Do **unplug** the Enclosure from the electrical outlet when not in use to provide an ecological friendly environment.
- ◆ **Use only** the power supply cable provided with the Enclosure.

INTRODUCTION

Thank you for purchasing the Crystal USB 3.0 3.5-inch HDD Enclosure. The Crystal USB 3.0 3.5-inch HDD Enclosure provides stylish yet ozone-friendly housing environment for any 3.5" SATA hard drive, with the new *SuperSpeed* USB 3.0 technology.

The installation instructions in this manual apply to the following models:

- ✚ HU-M10J (USB 2.0/3.0 combination)



Please thoroughly read and follow the instructions provided in this manual. Failure to do so may result in damage to the Enclosure, and any or all of the connected devices.

Features

- ✚ Supports SATA compliant hard drive
- ✚ Features hot-plug and hot-swap
- ✚ Increases heat dissipation and saves desktop space by utilizing an upright position so hot air can naturally float through the top panel ventilation holes
- ✚ Reveals instant status via hidden LED shining downward onto surface
- ✚ Provides steady and firm stance via curved rubber feet on the housing bottom panel
- ✚ Available data transfer speed up to 480Mbits/s (under USB 2.0) and up to 5Gbits/s (under USB 3.0)
- ✚ Reduces power consumption with hard drive spin up/down support
- ✚ Connects to host by plug-n-play, not requiring any IT expertise or software installation
- ✚ Powers on/off via USB cable instead of A/C adapter or power button
- ✚ Compatible with both Hi-Speed USB and SuperSpeed USB (USB 2.0 and 3.0)

SYSTEM REQUIREMENT

To use the Crystal USB 3.0 3.5-inch HDD Enclosure, the minimum system configuration in the host computer require the following:

PC

- ✚ 500MHz or faster CPU
- ✚ 256MB or higher RAM
- ✚ Microsoft Windows XP, 2003, Vista, 2008, 7 or higher
- ✚ One available USB 2.0 or USB 3.0 port

MAC

- ✚ Macintosh PowerPC or Intel processor
- ✚ 256MB or higher RAM
- ✚ Mac OS X 10.3 or higher
- ✚ One available USB 2.0 or USB 3.0 port

Optional Accessories

- ✚ USB 3.0 host card



Because many host computers do not feature USB 3.0 ports yet, an USB 3.0 PCI Express Card (for desktop computer) or an USB 3.0 ExpressCard 34 (for laptops) may be purchased to permit the maximum data speed possible when utilizing the Crystal USB 3.0 3.5-inch HDD Enclosure.

PACKAGE CONTENTS

To get started, please review the package contents for the chosen model.

HU-M10J

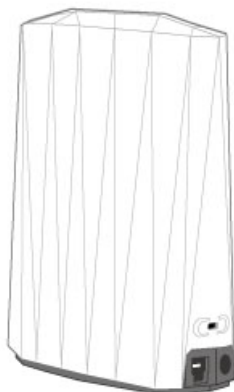

Enclosure

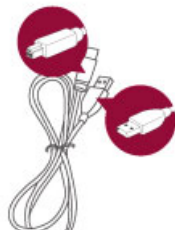

USB 3.0 Cable



AC/DC Adapter



2 HDD Screws

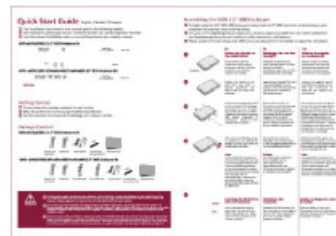

Quick Start Guide



Please keep all package contents and packaging material in the event that the product must be returned.

SYSTEM UNIT VIEWS

Rear/Front View

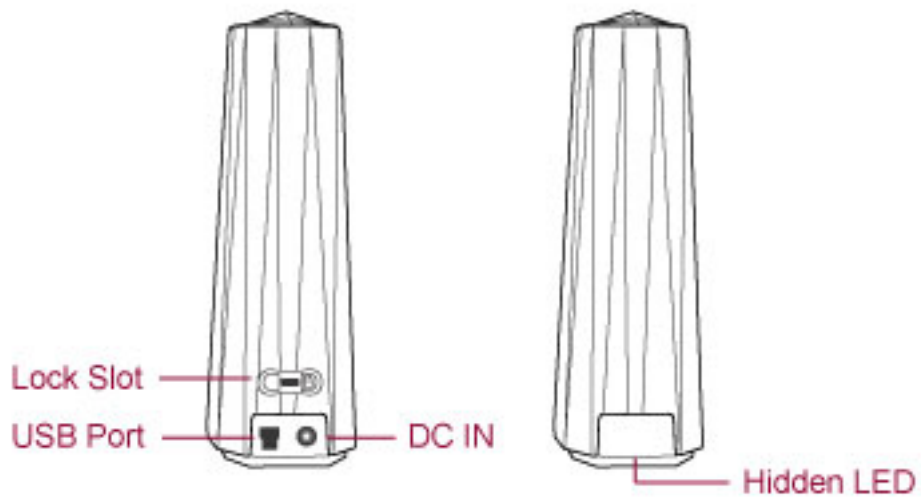

 The hidden LED will indicate the current operating status by shining downward onto the surface.

Bottom View

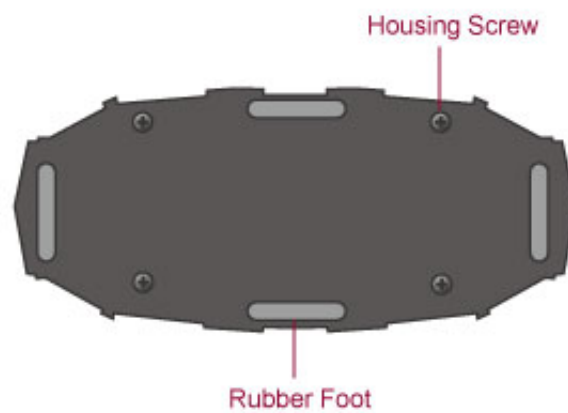

Inside View

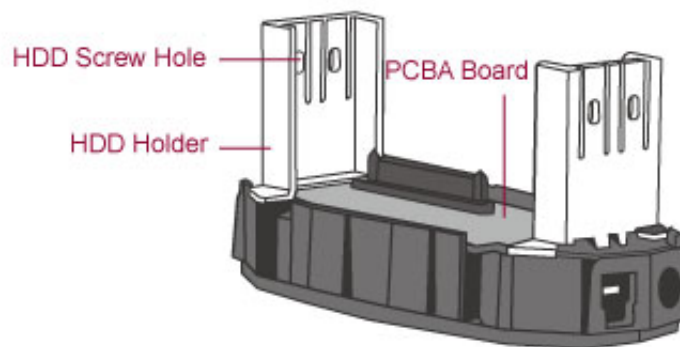

ASSEMBLING THE ENCLOSURE

To begin using the Crystal USB 3.0 3.5-inch HDD Enclosure, simply install a 3.5" SATA hard drive into the Enclosure by completing the following steps:



Partitioning and formatting operations will erase all existing data on the hard drive. Remember to backup all existing data from the hard drive before performing any partitioning or formatting operations to prevent loss of data.

1. Turn the Enclosure with its Bottom View facing you. Use a Philips Screw Driver and unscrew the four (4) larger Housing Screws.

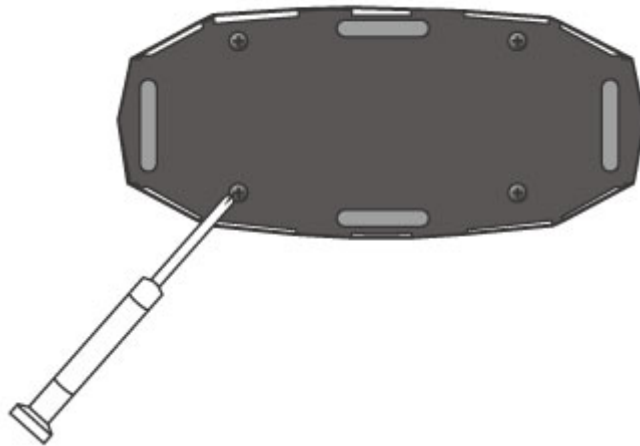

2. After removing the four (4) larger Housing Screw, turn the Enclosure back to upright standing position with its Rear View facing you. Hold the Bottom Base with one hand and pull upward on the Housing Case with the other hand.

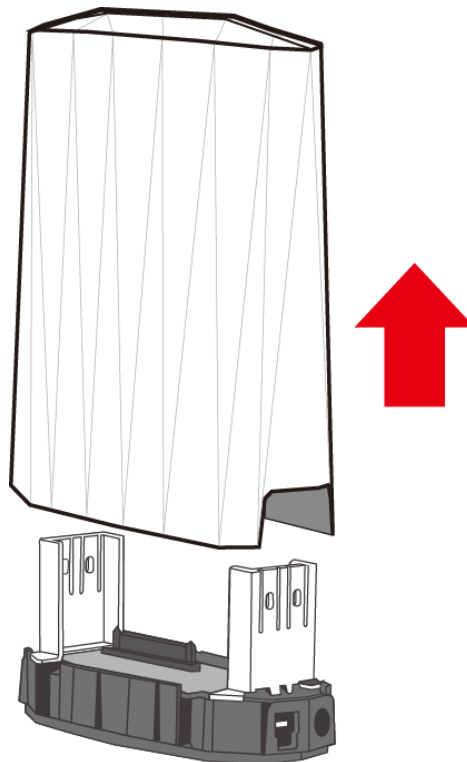

Once the Housing Case is removed, the PCBA board (Printed Circuit Board) and two (2) HDD Holders should be already securely installed onto the Bottom Base. See Inside View for reference. Also, find the two (2) HDD Screws included inside the package.

3. Then, place the 3.5-inch SATA hard drive into the two (2) HDD Holder slot on top of the Bottom Case. Make sure the hard drive and PCBA are aligned properly. Use a Philips Screw Driver and screw in one (1) HDD Screws on each side of the HDD Holder. Tighten the HDD Screws securely to ensure that proper alignment is maintained.

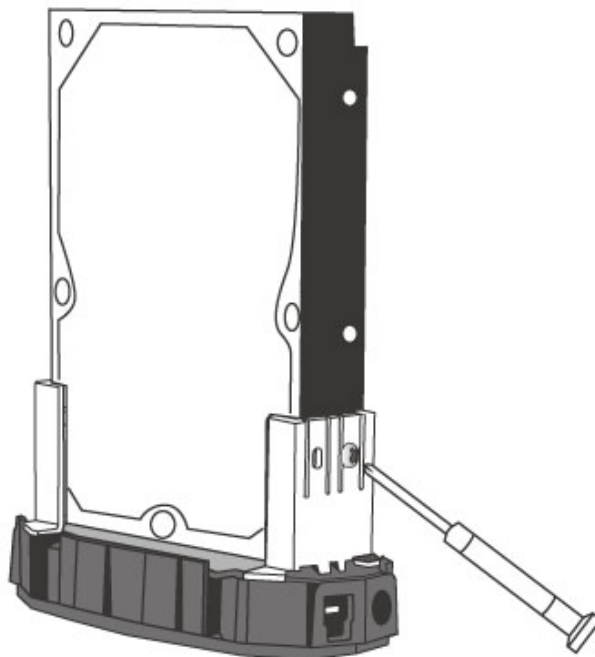

4. Once completed, replace the Housing Case back onto the Bottom Base and push downward. Use a Philips Screw Driver and re-screw the four (4) Housing Screws back onto the Bottom Base.

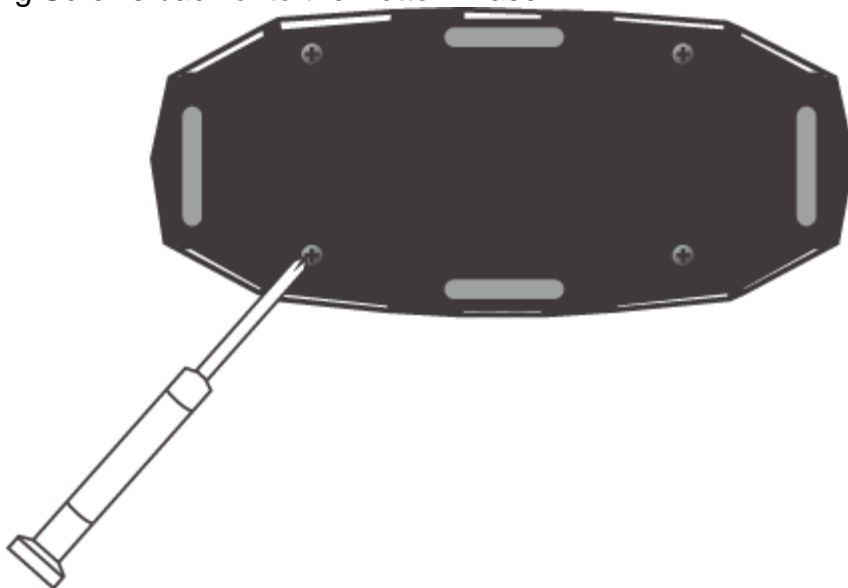

5. Now, the Enclosure Unit is ready for connection to a computer!

PUTTING ON & SWITCHING POWER PLUG ON AC/DC ADAPTER

1. Find the AC/DC Adapter in the package. The package may include different types of plug heads vary by region.

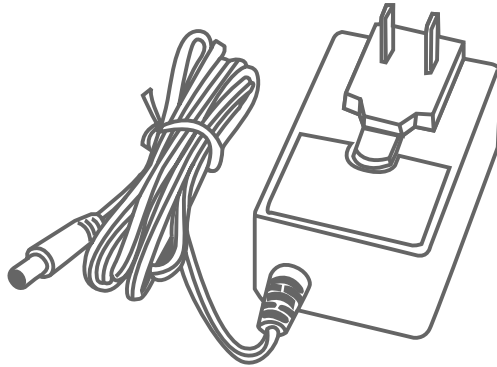

2. Press the click release and slide the existing Power Plug from the AC/DC Adapter.

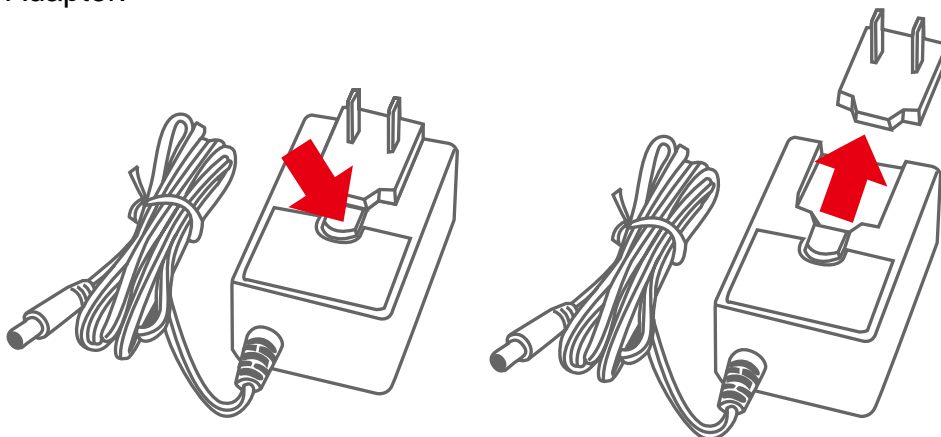

3. Slide the selected Power Plug onto the AC/DC adapter. Now, it is ready to be used!

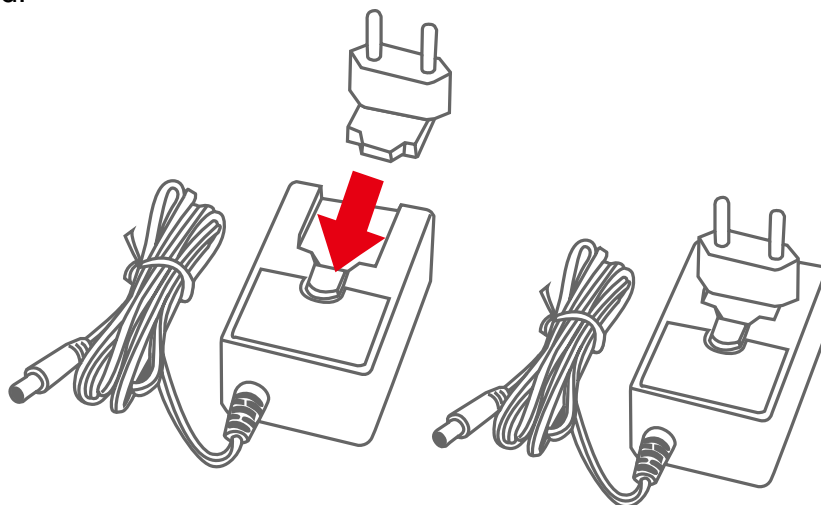

CONNECTING THE ENCLOSURE UNIT TO A COMPUTER

Complete the following steps to connect the Enclosure Unit to a host computer:



The Enclosure Unit should only be connected to a host computer via one interface at a time. Connection of the Enclosure Unit to a computer via two or more interfaces simultaneously is not recommended.

1. First, connect the AC/DC Adapter and the interface cable into the corresponding ports of Enclosure Unit. Next, insert the plug end of the AC/DC Adapter into an electrical plug.

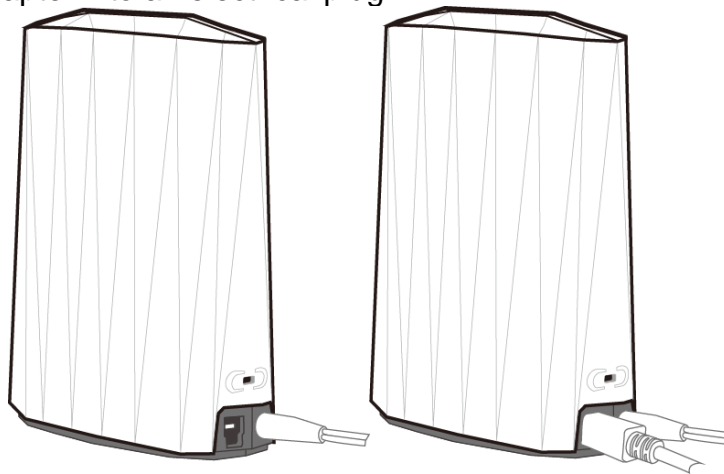

2. Then, insert the interface cable to the corresponding port of the host computer.

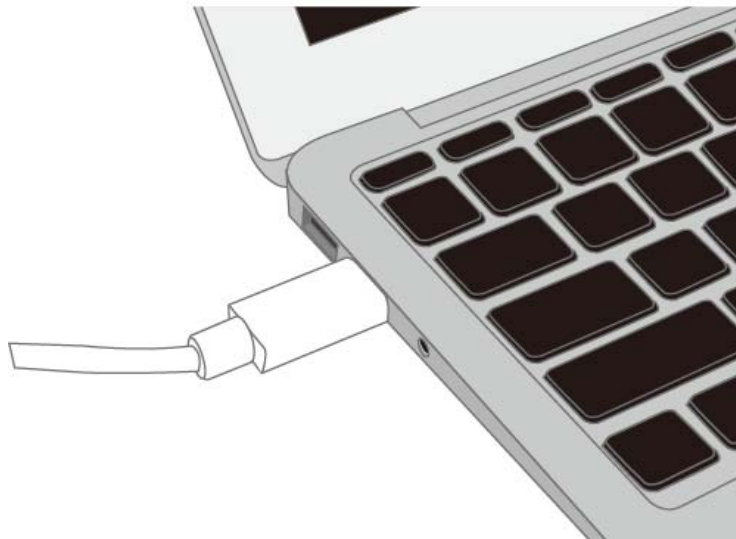

3. Once connected, the host computer should automatically detect the external Enclosure Unit and the hard drive should begin powering up. When the hard drive is powering up, the hidden LED will be blue. When the hard drive is being accessed, the hidden LED will flash in blue.

LED STATUS

LED COLOR	STATUS
BLUE	POWER ON
FLASHING BLUE	DATA ACCESS

SAFE REMOVAL OF THE ENCLOSURE

Safe removal of the Enclosure Unit from the host controller is highly recommended. In order to safely remove your Enclosure Unit from the host controller, you would need to eject the device on your host controller system.



If using a Mac System, safe removal of the Enclosure from the host for all interfaces is necessary.

EXTERNAL BOOTUP

External Bootup may be required if the user has two different operating systems set up in both the host computer and the Enclosure.

PC

The External Bootup with different interface:

OS \ Interfaces	USB 2.0/3.0
Windows	No
DOS	Yes
Linux	No

MAC

The External Bootup varies with different platform and interfaces:

Platform \ Interfaces		USB 2.0/3.0
Power PC CPU (G4 or Later)		No
Intel-based CPU	CoreDuo	Yes
	Core2Duo Or Later	Yes

Q&As

Hard Drive Capacity

Q: My hard drive is at least 2TB or above, will the Enclosure be able to support the gigantic storage capacity?

A: Yes, the Enclosure will be able to support any hard drive over 2TB size capacity.

Q: I would like to format my hard drives with the FAT (a.k.a. File Allocation Table) format, which can be read and written by both Mac and PC. Is there any limitation on its capacity?

A: Yes, please check the table below for reference.

File System	NTFS	FAT32	FAT (Format by Win2000/WinXP)	FAT16
Capacity Limitation	Vista: 16384TB XP: 2TB	Windows: 32GB Mac: 2TB	4GB	2GB

Discrepancy in Reported & Actual Size Capacity

Q: If I have a 750GB hard drive, why does the Enclosure only recognizes the hard drive available space as to be less than 750GB?

A: Many customers are confused by their host systems when it reports a discrepancy between reported capacity and actual capacity. Several factors can come into play when your host system views and reports the capacity of a hard drive. There are actually two different numbering systems used to express units of storage capacity:

Binary, which says that a kilobyte is equal to 1024 bytes; and
Decimal, which says that a kilobyte is equal to 1000 bytes.

Most commonly used to display storage capacity is in Decimal. The surprising fact is that even though it seems like you will have more bytes under Binary, the Decimal calculation system actually presents a greater storage capacity. More information on capacity issues can be found at the Seagate website under FAQs.

http://www.seagate.com/ww/v/index.jsp?locale=en-US&name=Storage_Capacity_Measurement_Standards_-_Seagate_Technology&vgnnextoid=9493781e73d5d010VgnVCM100000dd04090aRCRD

APPENDIX: SPECIFICATIONS

Model Name	HU-M10J
Connector	USB 2.0/3.0 x 1
HDD Support	3.5" SATA hard drive
Data Transfer Speed	USB 3.0: up to 5Gbits/s USB 2.0: up to 480Mbits/s
System Material	Plastic casing
Status Indicator	Power On / Access
Power Supply	Output: 12V/1.5A, Input: 100~240V Universal AC/DC adapter
Dimension	131 (L) x 63 (W) x 180 (H) mm
Weight (without hard drive)	220 g
Certification	CE, FCC, ErP/EuP